

AEL-EX24L High Output Slim Line LED Emergency EXIT Light

STANDARD FEATURES

HOUSING

- ❑ Aluminum cast housing
- ❑ Fire retardant acrylic material for display panel
- ❑ Knock-out hole for cable entry provision

DISPLAY

- ❑ Green or Red background, white text
- ❑ Maximum height & stroke of signage to comply with at least 12m distance visibility for persons with 20/20 vision
- ❑ Legend: ISO Green display

MOUNTING

- ❑ Wall or ceiling mount

PACKING SPECIFICATIONS

- ❑ 1 unit per individual box

STANDARD COMPLIANCE

- ❑ *NFPA 70, UL-90, IEC60598-2-22*

PRODUCT WARRANTY

- ❑ One Year for Parts
- ❑ Lifetime Free Service

ELECTRICAL FEATURES

ELECTRICAL

- ❑ 220~240 VAC 50/60Hz
- ❑ Low Power consumption
- ❑ Red LED charge monitor
- ❑ Convenient Push-Off test switch to simulate power failure

LIGHT SOURCE

- ❑ High Output 24-LED exceeding NFPA 70 Standard (> 80 lumens)
- ❑ 24-LED 5.0Ømm 6,500°K~6,000°K
- ❑ LEDs mounted on PCB

BATTERY

- ❑ *UL Listed Ni-Cd 3.6V 700mAh*

PERFORMANCE

- ❑ 2 ~ 3 hours ± 10% lighting duration
- ❑ Temperature Range – 10 °C to 55 °C

CHARGER

- ❑ 24 hours recharge period after discharge
- ❑ Low voltage battery (LBD) discharge disconnection to protect the battery from deep discharge damage to the battery



QUANTUM

QUANTUM ELECTRONICS CORPORATION

117 Tirad Pass Street, Caloocan City, Metro Manila, 1400
Telephone numbers: +63(2) 3634075 3634077 3527105
FAX# 632-3638087 e-mail: quantum_corp@yahoo.com.ph
Website: URL: <http://www.quantumelectronics.com.ph>

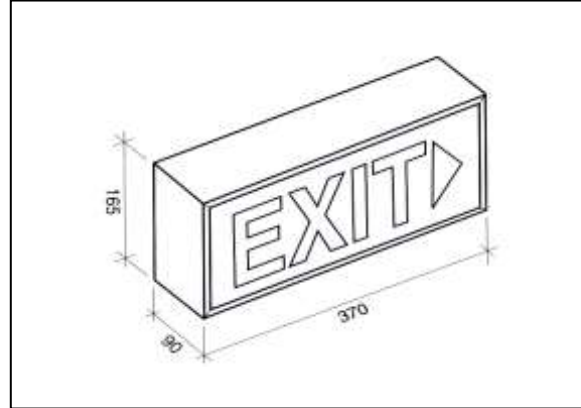

EEL-24LED-SF High Output EXIT (Box Type LED) LED Emergency EXIT Light

STANDARD FEATURES

HOUSING

- Powder epoxy paint steel body
- Acrylic material for display panel
- Single or double face configuration

DISPLAY

- Green background with white text
- Height & stroke of lettering as per customer's specification
- Single or double sided

MOUNTING

- Universal (Wall, side or ceiling mount)
- Knockouts for desired mounting position

PACKING SPECIFICATIONS

- 1 unit per individual box

PRODUCT WARRANTY

- One Year for Parts
- Lifetime Free Service

ELECTRICAL FEATURES

ELECTRICAL

- 220~240 VAC 50/60Hz
- Power consumption @ 3 Watts
- LED charge monitor

LIGHT SOURCE

- 30,000 hours lifespan
- 24-LED 5.0Ømm 6,000°K
- LEDs mounted on PCB

BATTERY

- UL Listed* Ni-Cd 3.6V 700mAh

PERFORMANCE

- 2 hours \pm 10% lighting duration

CHARGER

- 24 hours recharge period after discharge
- Low voltage battery (LBD) discharge disconnection to protect the battery from deep discharge damage to the battery

Specification and Design Improvements are Subject to Change Without Prior Notice



QUANTUM

QUANTUM ELECTRONICS CORPORATION

117 Tirad Pass Street, Caloocan City, Metro Manila, 1400
Telephone numbers: +63(2) 3634075 3634077 363-5573
FAX# 632-3638087 e-mail: quantum_corp@yahoo.com.ph
Website: URL: www.quantumelectronics.com.ph

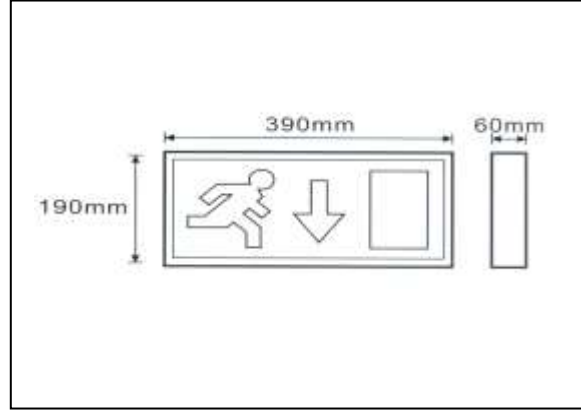

EEL-LED165 High Output EXIT LED Emergency EXIT Light

STANDARD FEATURES

HOUSING

- Powder epoxy paint steel body
- Acrylic material for display panel
- Single or double face configuration

DISPLAY

- Green background with white text
- Height & stroke of lettering as per customer's specification
- Single or double sided

MOUNTING

- Universal (Wall, side or ceiling mount)
- Knockouts for desired mounting position

PACKING SPECIFICATIONS

- 1 unit per individual box

PRODUCT WARRANTY

- One Year for Parts
- Lifetime Free Service

ELECTRICAL FEATURES

ELECTRICAL

- 220~240 VAC 50/60Hz
- Power consumption @ 3 Watts
- LED charge monitor

LIGHT SOURCE

- 30,000 hours lifespan
- 24-LED 5.0Ømm 6,000°K
- LEDs mounted on PCB

BATTERY

- UL Listed Ni-Cd 3.6V 700mAh

PERFORMANCE

- 2 hours \pm 10% lighting duration

CHARGER

- 24 hours recharge period after discharge
- Low voltage battery (LBD) discharge disconnection to protect the battery from deep discharge damage to the battery

Specification and Design Improvements are Subject to Change Without Prior Notice



QUANTUM ELECTRONICS CORPORATION
117 Tirad Pass Street, Caloocan City, Metro Manila, 1400
Telephone numbers: +63(2) 3634075 3634077 3527105
FAX# 632-3638087 e-mail: quantum_corp@yahoo.com.ph
Website: URL: <http://www.quantumelectronics.com.ph>

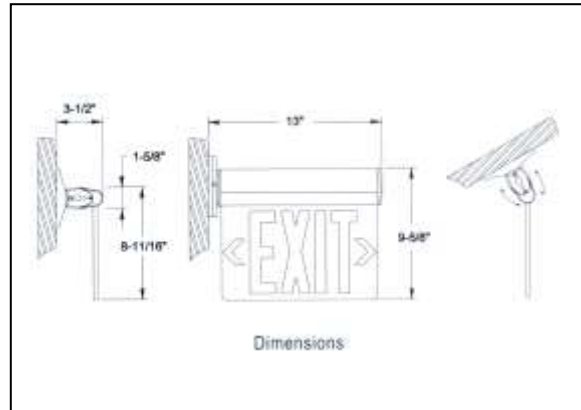

ELS-800S Single Face
ELS-800D Double Face

STANDARD FEATURES

HOUSING

- Aluminum housing body
- High grade acrylic panel
- EXIT pivot for wall, ceiling, sloped ceiling

DISPLAY

- Removable directional indicators
- Height lettering at 6" with 3/4 stroke
- Single or double sided configuration

MOUNTING

- Wall, end or ceiling mount
- Pendant mounting provision

PACKING SPECIFICATIONS

- 1 unit per individual box

PRODUCT WARRANTY

- One Year for Parts
- Lifetime Free Service

ELECTRICAL FEATURES

ELECTRICAL

- 220~240 VAC 50/60Hz
- Low energy consumption
- LED indicator & test switch

LIGHT SOURCE

- 30,000 hours lifespan
- High output LED 5.0 Ømm
- LEDs mounted on PCB

BATTERY

- UL Listed* Ni-Cd Battery Pack

PERFORMANCE

- 3 hours \pm 10% lighting duration

CHARGER

- 24 hours recharge period after discharge
- Low voltage battery (LBD) discharge disconnection to protect the battery from deep discharge damage to the battery

Specification and Design Improvements are Subject to Change Without Prior Notice



QUANTUM ELECTRONICS CORPORATION

117 Tirad Pass Street, Caloocan City, Metro Manila, 1400

Telephone numbers: +63(2) 3634075 3634077 3527105

FAX# 632-3638087 e-mail: quantum_corp@yahoo.com.ph

Website: URL: <http://www.quantumelectronicscorporation.yolasite.com>



QUANTUM

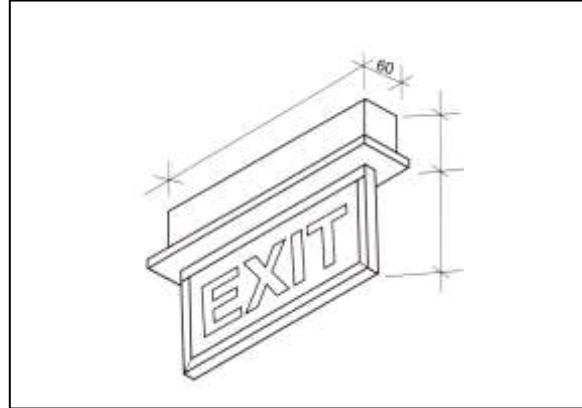

ELS-T5-LED EXIT Light LED Emergency EXIT Light

STANDARD FEATURES

HOUSING

- Electro-galvanized steel with epoxy powder paint coating
- Acrylic plate
- Single edge light acrylic plate

DISPLAY

- Green background with white text
- Height & stroke of lettering as per customer's specification

MOUNTING

- Wall, side or ceiling mount

PACKING SPECIFICATIONS

- 1 unit per individual box
- 395mm x 280mm x 60mm (LHW)

PRODUCT WARRANTY

- One Year for Parts
- Lifetime Free Service

ELECTRICAL FEATURES

ELECTRICAL

- 220~240 VAC 50/60Hz
- Power consumption less than 4 Watts
- LED charge monitor

LIGHT SOURCE

- 30,000 hours lifespan
- T5-LED tube or 24-LED arrays
- 5,000 °K white

BATTERY

- UL Listed Ni-Cd 3.6V 2,000mAh

PERFORMANCE

- 3 hours \pm 10% lighting duration

CHARGER

- 24 hours recharge period after discharge
- Low voltage battery (LBD) discharge disconnection to protect the battery from deep discharge damage to the battery

Specification and Design Improvements are Subject to Change Without Prior Notice

BYY-LED Series Explosion Proof Signage

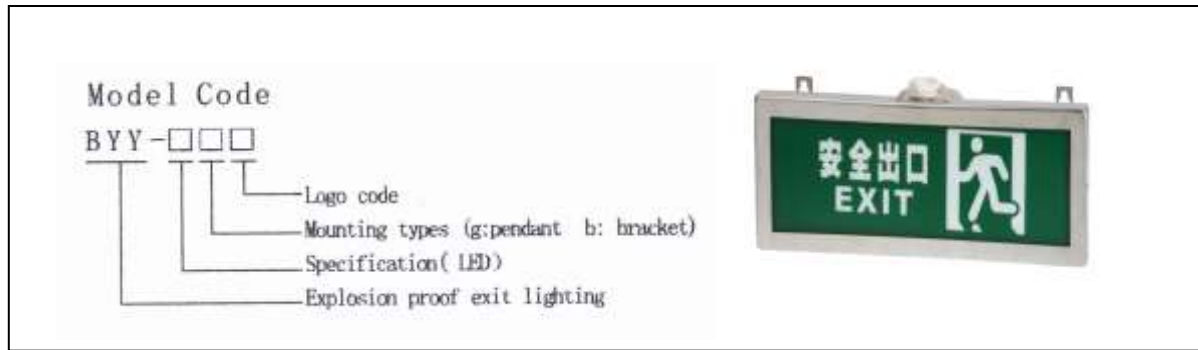

Outline and Installation dimensions

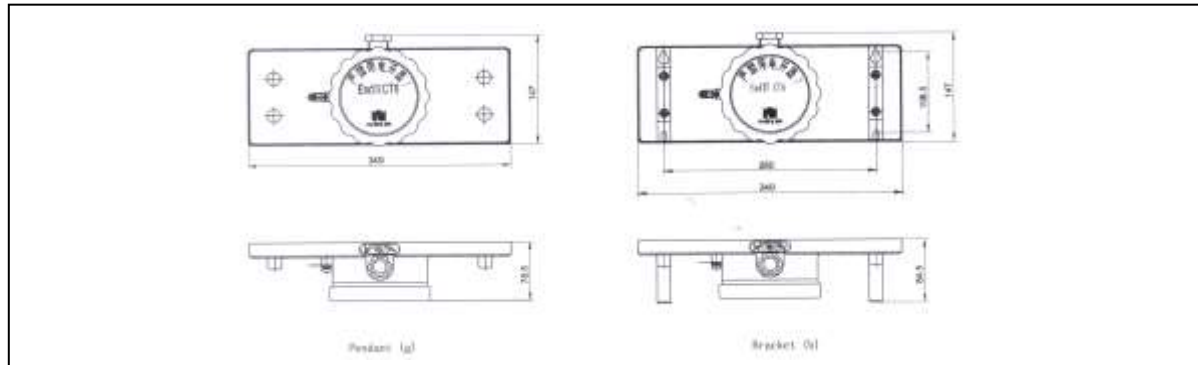

BYD Series Explosion Proof EXIT Lighting (IIC, DIP) Ex-mark: ExdIICT4

STANDARD FEATURES

HOUSING

- Aluminum alloy cast enclosure
- Surface coated with plastic fine outline
- Signage layout can be specified

MOUNTING

- Pendant (g)
- Bracket (b)

WIRING

- Inlet thread (G) ¾
- Cable Outer diameter: Ø10 ~ Ø14

APPLICATIONS

- Explosive Atmosphere Zone 1 & Zone 2
- Combustible dust Zone 20, 21 and 22
- Designed for Groups IIA, IIB, IIC
- Temperature Classes T1 ~ T6
- Ingress Protection: IP65

PRODUCT WARRANTY

- One Year for Parts

ELECTRICAL FEATURES

ELECTRICAL

- 220~240 VAC 50/60Hz
- Rated power 5W
- Emergency power ≤ 1 Watt
- Emergency switchover ≤ 0.3 s

LIGHT SOURCE

- High brightness HB LED with long service life of 50,000 hours

BATTERY

- Rechargeable Lithium Cell 3.2V

EMERGENCY LIGHTING DURATION

- 48 hours ± 10% lighting duration

STANDARD COMPLIANCE

- IEC60079-0
- IEC60079-1
- GB 3836-1 & 2
- GB 12476-1
- GB 61241-1-1



QUANTUM

QUANTUM ELECTRONICS CORPORATION

No. 117 Tirad Pass Street, Caloocan City, Metro Manila

Telephone: +63(2) 363-4075 363-4077 363-5573

FAX No. 363-8087 e-mail: quantum_corp@yahoo.com.ph

Website: URL: <http://www.quantumelectronics.com>



**EX-800GX-Green Compact Version
LED Emergency EXIT Light**

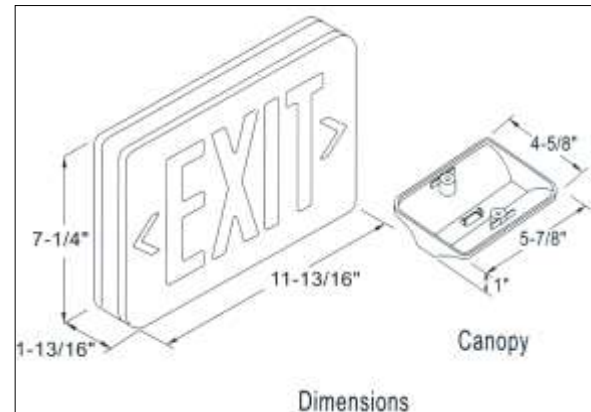

STANDARD FEATURES

HOUSING

- Injection molded ABS housing
- UL-90V-0 flame rating
- Replaceable directional chevron inserts
- Standard 6" letter height with 3/4" stroke
- Single or double face configuration

MOUNTING

- Universal (Wall, side or ceiling mount)
- Housing snaps to canopy with simple twist and locking mechanism

PACKING SPECIFICATIONS

- 12 units per master box @14.5kgs.
- 300mm x 186mm x 46mm (LWH)

PRODUCT WARRANTY

- One Year for Parts
- Lifetime Free Service

ELECTRICAL FEATURES

ELECTRICAL

- 220~240 VAC 50/60Hz
- Power consumption @ 2 Watts
- LED charge monitor

LIGHT SOURCE

- 30,000 hours lifespan
- Green LED 5.0Ømm
- LEDs mounted on PCB

BATTERY

- UL Listed Ni-Cd 2.4V 300mAh

PERFORMANCE

- 2 hours ± 10% lighting duration

CHARGER

- 24 hours recharge period after discharge
- Low voltage battery (LBD) discharge disconnection to protect the battery from deep discharge damage to the battery

Specification and Design Improvements are Subject to Change Without Prior Notice



QUANTUM

QUANTUM ELECTRONICS CORPORATION

117 Tirad Pass Street, Caloocan City, Metro Manila, 1400
Telephone numbers: +63(2) 3634075 3634077 363-5573
FAX# 632-3638087 e-mail: quantum_corp@yahoo.com.ph
Website: <http://www.quantumelectronics.com.ph>



**FEL-36V High Output EXIT (Box Type LED)
LED Emergency EXIT Light**

STANDARD FEATURES

HOUSING

- Powder epoxy paint steel body
- Acrylic material for display panel
- Single or double face configuration

DISPLAY

- Green background with white text
- 15.5cm Height & 19mm wide stroke of lettering.

MOUNTING

- Universal (Wall, side or ceiling mount)
- Knockouts for desired mounting position

PACKING SPECIFICATIONS

- 1 unit per individual box

PRODUCT WARRANTY

- One Year for Parts
- Lifetime Free Service

ELECTRICAL FEATURES

ELECTRICAL

- 220~240 VAC 50/60Hz
- Power consumption @ 3 Watts
- LED charge monitor

LIGHT SOURCE

- 30,000 hours lifespan
- 24-LED 5.0Ømm 6,000°K
- LEDs mounted on PCB

BATTERY

- UL Listed* Ni-Cd 3.6V 700mAh

PERFORMANCE

- 2 hours \pm 10% lighting duration

CHARGER

- 24 hours recharge period after discharge
- Low voltage battery (LBD) discharge disconnection to protect the battery from deep discharge damage to the battery

Specification and Design Improvements are Subject to Change Without Prior Notice



QUANTUM

QUANTUM ELECTRONICS CORPORATION

117 Tirad Pass Street, Caloocan City, Metro Manila, 1400

Telephone numbers: +63(2) 3634075 3634077 352-7105

FAX# 632-3638087 e-mail: quantum_corp@yahoo.com.ph

Website: URL: <http://www.quantumelectronics.com.ph>

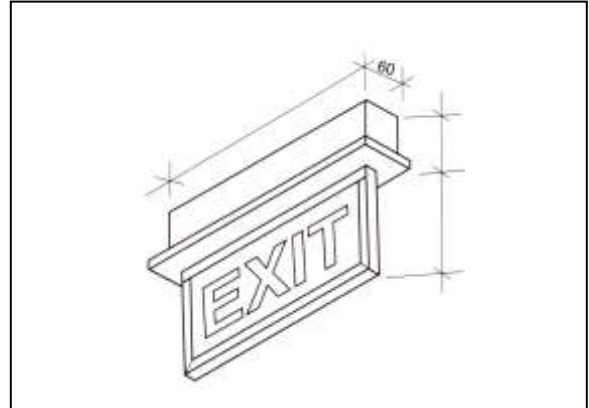

ESL-LED EXIT Light LED Emergency EXIT Light

STANDARD FEATURES

HOUSING

- Electro-galvanized steel with epoxy powder paint coating
- Acrylic plate for single or double face display

DISPLAY

- Green background with white text or as per customer's specification
- Height & stroke of lettering as per customer's specification

MOUNTING

- Recessed

PACKING SPECIFICATIONS

- 1 unit per individual box
- 395mm x 280mm x 60mm (LHW)
- Available in smaller dimensions

PRODUCT WARRANTY

- One Year for Parts
- Lifetime Free Service

ELECTRICAL FEATURES

ELECTRICAL

- 220~240 VAC 50/60Hz
- Power consumption less than 4 Watts
- LED charge monitor
- Remote Test Switch

LIGHT SOURCE

- 30,000 hours lifespan
- 24 high output LED arrays
- 5,000 °K white

BATTERY

- UL Listed* Ni-Cd 3.6V 700mAh

PERFORMANCE

- 2 hours \pm 10% lighting duration

CHARGER

- 48 hours recharge period after discharge
- Low voltage battery (LBD) discharge disconnection to protect the battery from deep discharge damage to the battery

Specification and Design Improvements are Subject to Change Without Prior Notice

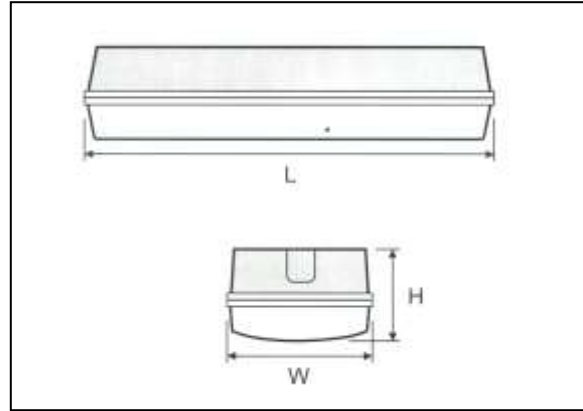

**TY-SBL IP65 Fire Retardant EXIT
 LED Emergency EXIT Light**

STANDARD FEATURES

HOUSING

- Polycarbonate material
- 3M heat resistant adhesive film
- Insect proof, dust proof, waterproof

DISPLAY

- Green background with white text
- Height & stroke of lettering as per customer's specification

MOUNTING

- Universal (Wall, side or ceiling mount)

PACKING SPECIFICATIONS

- 10 units per individual box
- 347 x 106 x 81 m/m

PRODUCT WARRANTY

- One Year for Parts
- Lifetime Free Service

ELECTRICAL FEATURES

ELECTRICAL

- 220~240 VAC 50/60Hz
- Power consumption @ 3 Watts
- LED charge monitor

LIGHT SOURCE

- 30,000 hours lifespan
- LED 5.0Ømm arrays
- CCT 4,500°K~6,000°K

BATTERY

- UL Listed* Ni-Cd 3.6V 700mAh

PERFORMANCE

- 2 hours ± 10% lighting duration

CHARGER

- 48 hours recharge period after discharge
- Low voltage battery (LBD) discharge disconnection to protect the battery from deep discharge damage to the battery